

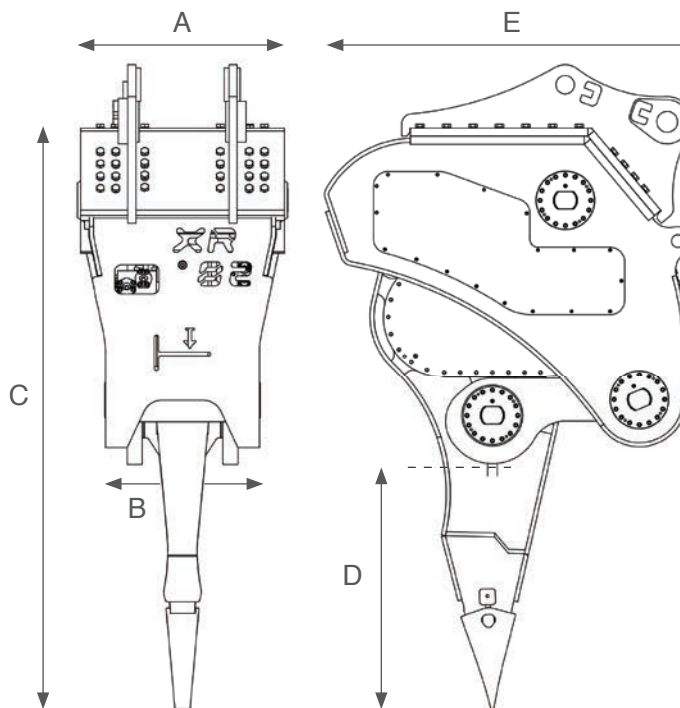

XR 62



TECHNICAL SPECIFICATIONS		XR62
Excavator weight	Tons	55 - 70
Ripper operating weight (incl. top bracket)	kg	7.600
Ripper operating weight (top bracket not included)	kg	6.330
Hydraulic working pressure	MPa	28
Hydraulic oil flow	L/min	280
Frecuency	1/min	1.100



XR62	
A	1.100
B	1.100
C	3.450
D	1.380
E	2.170

* Dimensions in millimeters.

XCENTRIC RIPPER INTERNATIONAL, S.L.

Arriurdina, 15 · 01015 Vitoria-Gasteiz (Spain) · Tel.: +34 945 290 555

www.xcentricripper.com