

Preliminary

MHL 320 MODULAR⁺



95/97 kW



75 kW



19.3–21.5 t



max. 10.4 m



FUCHS[®]

A TEREX BRAND

MODULAR DRIVE SYSTEM



DIESEL ENGINE

Proven for decades and cleaner than ever before thanks to state-of-the-art exhaust gas filtration. Now you have a choice – also for diesel engines: Deutz or Cummins. Choose your preferred manufacturer.*



ELECTRIC MOTOR + DIESEL POWER PACK

With our classic Powerpack, you can noticeably expand the range of applications of your electrically powered FUCHS material handler. A small diesel power pack in combination with a special hydraulic pump provides enough power to move the machine and use all other functions with reduced speed. Perfect for driving from socket to socket.



ELECTRIC MOTOR

On the way to zero emissions, FUCHS electric machines are the first choice. Whether feeding balers and shredders, or stationary pre-sorting. With FUCHS electric material handlers, you can do all your work reliably, quietly and sustainably.



ELECTRIC MOTOR + BATTERY PACK

Our latest innovation. With the battery power pack, your MHL320 MODULAR⁺ can be operated semistationary in grid mode or fully flexible in battery mode. Without any local emissions and with 100% power. The battery power pack can be scaled and (as a small world premiere) retrofitted.*



*Availability varies depending on model

TECHNICAL DATA

OPERATING WEIGHT WITHOUT ATTACHMENTS

MHL320 MODULAR ⁺	19.3–21.5 t *
-----------------------------	---------------

Diesel engine

	EU Stage V / U.S. Tier 4	EU Stage IIIA / U.S. Tier 3 **	EU Stage V / U.S. Tier 4
Manufacturer and model	Deutz TCD 3.6 L04	Deutz TCD 3.6 L04	Cummins F3.8
Design	4-cylinder in-line engine	4-cylinder in-line engine	4-cylinder in-line engine
Functionality	4-cycle diesel, common rail direct injection, turbocharged with intercooler, controlled exhaust gas recirculation, diesel particulate filter with continuous regeneration and SCR catalytic converter	4-cycle diesel, common rail direct injection, turbocharged with intercooler	4-cycle diesel, common rail direct injection, turbocharged with intercooler, diesel particulate filter with continuous regeneration and SCR catalytic converter
Engine power	95 kW	95 kW	97 kW
Rated speed	1800 rpm	1800 rpm	1800 rpm
Displacement	3.6 l	3.6 l	3.8 l
Cooling system	Water and charge air cooling with demand driven, temperature-dependent fan drive and reversible fan	Water and charge air cooling with demand driven, temperature-dependent fan drive and reversible fan	Water and charge air cooling with demand driven, temperature-dependent fan drive and reversible fan
Exhaust emission standard	EU Stage V / U.S. Tier 4 / China 4	EU Stage IIIA / U.S. Tier 3*	EU Stage V / U.S. Tier 4
Fuel tank	275 l	275 l	275 l
Urea Tank (AdBlue)	20 l	□	37.9 l

Electrical system

Alternator	28 V / 100 A	28 V / 100 A	28V / 90A
Operating voltage	24 V		
Battery	2 × 12 V / 110 Ah / 750 A (according to EN)		
Lighting system	2 × LED floodlights at the front of the machine, rear parking lights and indicator lights, 2 × LED working lights on cab		

Electric motor

Power	75 kW
Total connected load	100 kW
Motor start	Via soft start
Optional cable reel	Up to 50 metres (other lengths on request)

Electric Motor + Battery Pack (enables grid independent driving & working at full power)

Battery capacity	66 kWh (Basic)
Battery type	Li-Ion Battery
Full charge cycles	Min. 3.000
Others	Scalable or retrofittable

Electric motor + diesel power pack (enables grid independent driving)

Engine power (Diesel Power Pack)	36.4 kW
Exhaust emission standard	EU Stage V / U.S. Tier 4
Types	Integrated or mobile

Travel drive

Hydrostatic travel drive via infinitely variable axial piston motor with directly mounted travel brake valve, two-speed manual gearshift, 4-wheel drive	
Travel speed 1st gear	max. 5 kph
Travel speed 2nd gear	max. 19 kph
Gradeability	max. 40 %
Turning radius	7.1 m
Turning radius with all-wheel steering	4.5 m

* without Battery Pack

** for low-regulated markets

TECHNICAL DATA

Slewing drive

Slewing ring	Internally geared, double-row ball turning ring, greasing via automatic lubrication system
Drive	2-stage planetary gear with integrated multi-disc brake
Uppercarriage swing speed	0–8 rpm
Slewing lock	Electrically activated

Undercarriage

Front axle	Planetary drive axle with integrated drum brake, rigidly mounted
Rear axle	Oscillating planetary drive rear axle with integrated drum brake and selectable oscillating lock
Outrigger	4-point stabilizers 2-point-stabilizers with support blade
Tires	10.00-20 solid rubber with intermediate rings

Brakes

Service brake	Hydraulic single-circuit braking system acting on all four wheel pairs (drum brakes)
Parking brake	Electrically operated spring-loaded drum brake at transmission, acting on both front and rear axle

Hydraulic system

Variable-displacement axial-piston pump	With load sensing, coupled with load-independent flow distribution, simultaneous independent control of all working functions
Max. pump capacity	305 lpm
Max. operating pressure	320 / 350 bar
Hydraulic oil tank	272 l
Filtration	Flow-optimized return filters, integrated in the oil tank. Filter fineness defined at a beta value $\beta(10) = 200$ guarantees 99.5% separation of dirt particles with 10 μm . Very good separation values are already achieved with particle sizes of 3 μm . Generously dimensioned for long operating times.
Cooling system	Separated high-performance cooler with demand driven, temperature-dependent fan drive and reversible fan

Operator's cab

Cab	Infinitely variable hydraulic height-adjustable cabin with sliding door. Reinforced steel structure, soundproofed, heat-insulated panoramic windows for best all-round visibility, front window with roller blind, glass panel in the cabin roof with sliding blind. Heating and air conditioning, separate heat exchangers, fresh and recirculated air filters. Multifunction touch display, bottle holder, paper clip and multiple storage and mounting options. Digital radio (DAB+, USB, Bluetooth and hands-free), USB charging station 5V. Infinitely variable hydraulic height-adjustment with eye level up to 5.3 m above ground
Air conditioning	Automatic air-conditioning. Hot water heating with variable temperature control and 8-speed fan, 10 adjustable air nozzles, 3 defroster nozzles
Operator's seat	Air-cushioned comfort seat with swinging armrests / joysticks, safety belt, lumbar support and headrest. Enables fatigue-free work due to universal adjustment options for the seat position, seat inclination and the arrangement of the seat cushion in relation to the armrests and joysticks.
Monitoring	Ergonomically arranged, glare-free Multifunction display. Automatic monitoring and storage of deviating operating states (e.g. all hydraulic oil filters, hydraulic oil temperature – coolant and charge air temperature – diesel particulate filter loading, steering), visual and audible warning. Diagnostic option for the individual sensors via the multifunction display. Rear view and side view camera on the right with separate monitor.

	EU Stage V/ U.S. Tier 4	EU Stage IIIA/ U.S. Tier 3*	EU Stage V/ U.S. Tier 4
Noise level	Sound power level (ambience) L_{WA} 97.7 dB(A) (metered) acc. to directive 2000/14/EC L_{WA} 99 dB(A) (guaranteed) acc. to directive 2000/14/EC Sound pressure level (inside the cabin) acc. to standard ISO 6396 L_{pA} 72 dB(A)	Sound power level (ambience) L_{WA} 99,3 dB(A) (metered) acc. to directive 2000/14/EC L_{WA} 100 dB(A) (guaranteed) acc. to directive 2000/14/EC Sound pressure level (inside the cabin) acc. to standard ISO 6396 L_{pA} 69 dB(A)	Sound power level (ambience) 
Vibrations	Weighted r.m.s. value of acceleration of upper limbs under 2.5 m/s ² (98 in/s ²) Weighted effective value of acceleration for the seat and feet under 0.5 m/s ² (20 in/s ²)		

Certified in accordance with CE regulations

EQUIPMENT

Diesel Engine	Standard	Option
Direct electronic fuel injection / common rail	●	
ECO and Power Mode	●	
Water and charge air cooler	●	
DEF injection, passive regeneration	●	
Advanced automatic idle incl. engine shut-off function	●	
Engine diagnostics interface	●	
Separated high-performance cooler with demand driven, temperature-dependent fan drive and reversible fan	●	
Engine preheating		●
Undercarriage		
All-wheel drive	●	
All-wheel steering		●
Low-maintenance drum brakes	●	
Rear axle oscillating lock	●	
2-speed powershift transmission		●
2-speed manual transmission	●	
4-point stabilizers	●	
Dozer blade in addition to 4-point stabilizers		●
2-point stabilizers and support blade		●
Stabilizer cylinders with integrated two-way check valves	●	
Piston rod protection on stabilizer cylinders	●	
Tool box	●	
Special paint (customer paint work)		●
Solid rubber tires (10.00-20) with intermediate rings	●	
Uppercarriage		
Separated high-performance cooling system for engine, acc and hydraulic systems	●	
Reversible and adjustable fan drives	●	
Automatic central lubrication system	●	
Rear view camera	●	
Side view camera	●	
Service platform	●	
Electric refuelling pump		●
Light protection		●
Operator's Cab		
Vertically adjustable cabin	●	
Single-pane safety glass (ESG)	●	
Sliding window in cab door	●	
Cabin with penetration resistant glass front and top (classification P5A)		●
Cabin with bullet-proof glass (classification P8B)		●
Windshield washer system	●	

EQUIPMENT

Operator's Cab	Standard	Option
Washing device for roof window		•
Air-cushioned operator seat with headrest, seatbelt and lumbar support	•	
Seat heating		•
Joystick steering	•	
Steering column, height and tilt adjustable		•
Automatic air conditioning	•	
Auxiliary heating		•
Multi-function display	•	
Document net	•	
Bottle holder with cooling	•	
FOPS guard		•
12 V transformer		•
Digital radio (DAB+, USB, Bluetooth and hands-free system)	•	
12V socket / cigarette lighter		•
Fire extinguisher, dry powder		•
Travel alarm w/ rotating beacon		•
Other Equipment		
9 kW DC generator		•
11 kW DC generator		•
Close proximity range limiter for dipperstick	•	
Coolant and hydraulic oil level monitoring system	•	
Overload and working area control		•
Filter system for attachments		•
Rupture valves for lifting cylinders		•
Rupture valves for stick cylinders		•
Overload warning device		•
Quick coupling on dipperstick	•	
Stick protection		•
Active cyclone prefilter (TOP AIR)		•
Hydraulic oil preheating		•
Lubrication of the grab suspension by central lubrication system	•	
Basic LED light packages		•
Power LED light packages		•
Basic LED head lights at the front of the machine	•	
Basic LED working lights cabin roof front	•	
Boom cylinder damping system (piston accumulator)		•
Paint color according to customer's request		•
Fuchs Telematics System, incl. 5 years contract	•	

DIMENSIONS

4-point stabilizers

Side view

all dimensions in mm

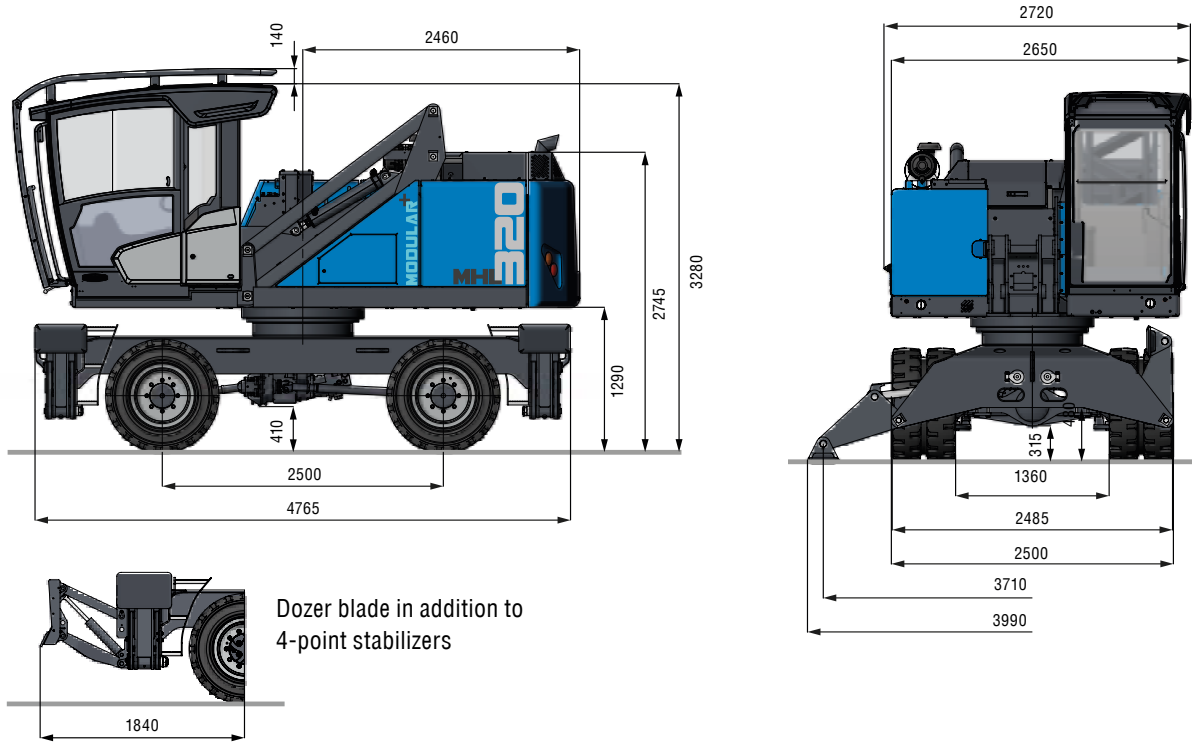

2-point Stabilizers and support blade

Side view

all dimensions in mm

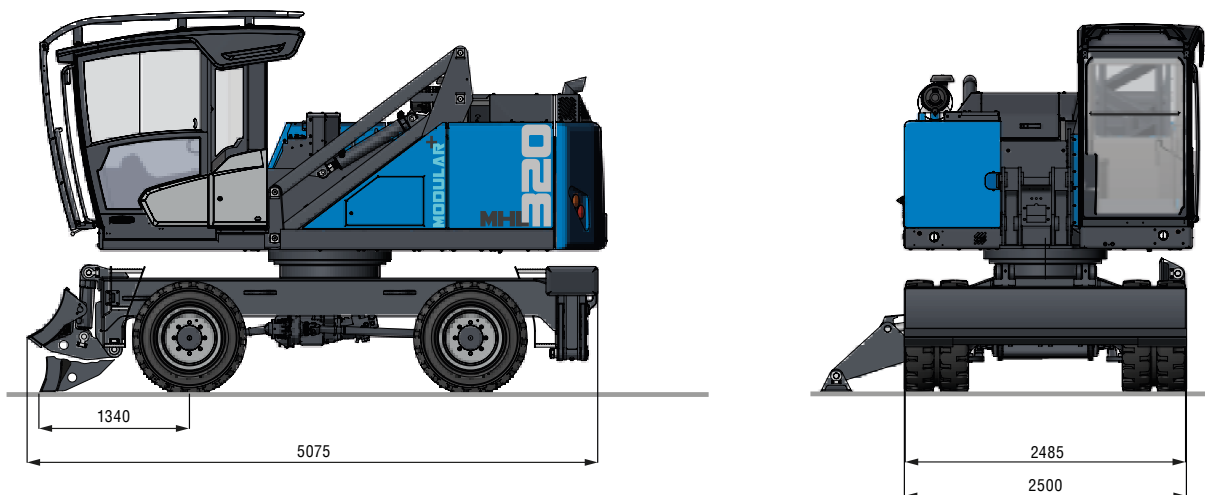



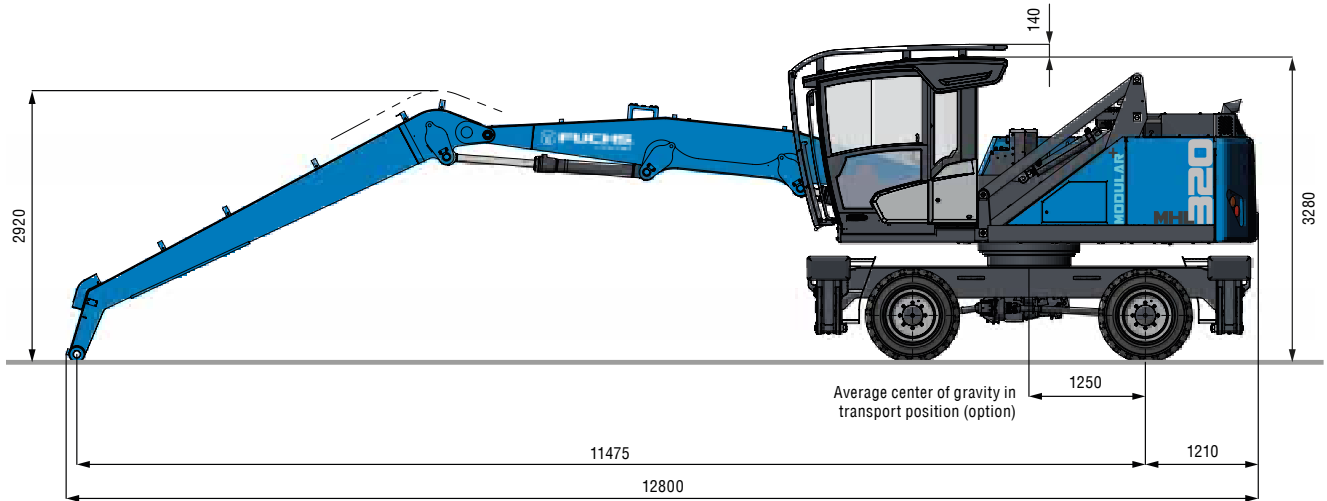
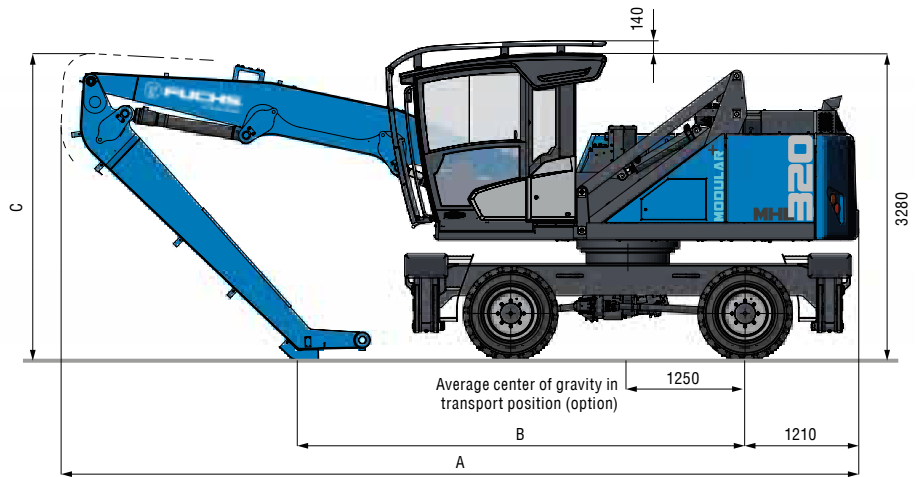

TRANSPORT DIMENSIONS

Side view

all dimensions in mm



	 8.2 m **	 9.2 m**	 9.5 m	 10.4 m
A	7545 mm	8625 mm	8510 mm	8070 mm
B	3480 mm	4140 mm	4745 mm	4035 mm
C	3150 mm	2850 mm	3275 mm	4825 mm

** Multi-purpose stick







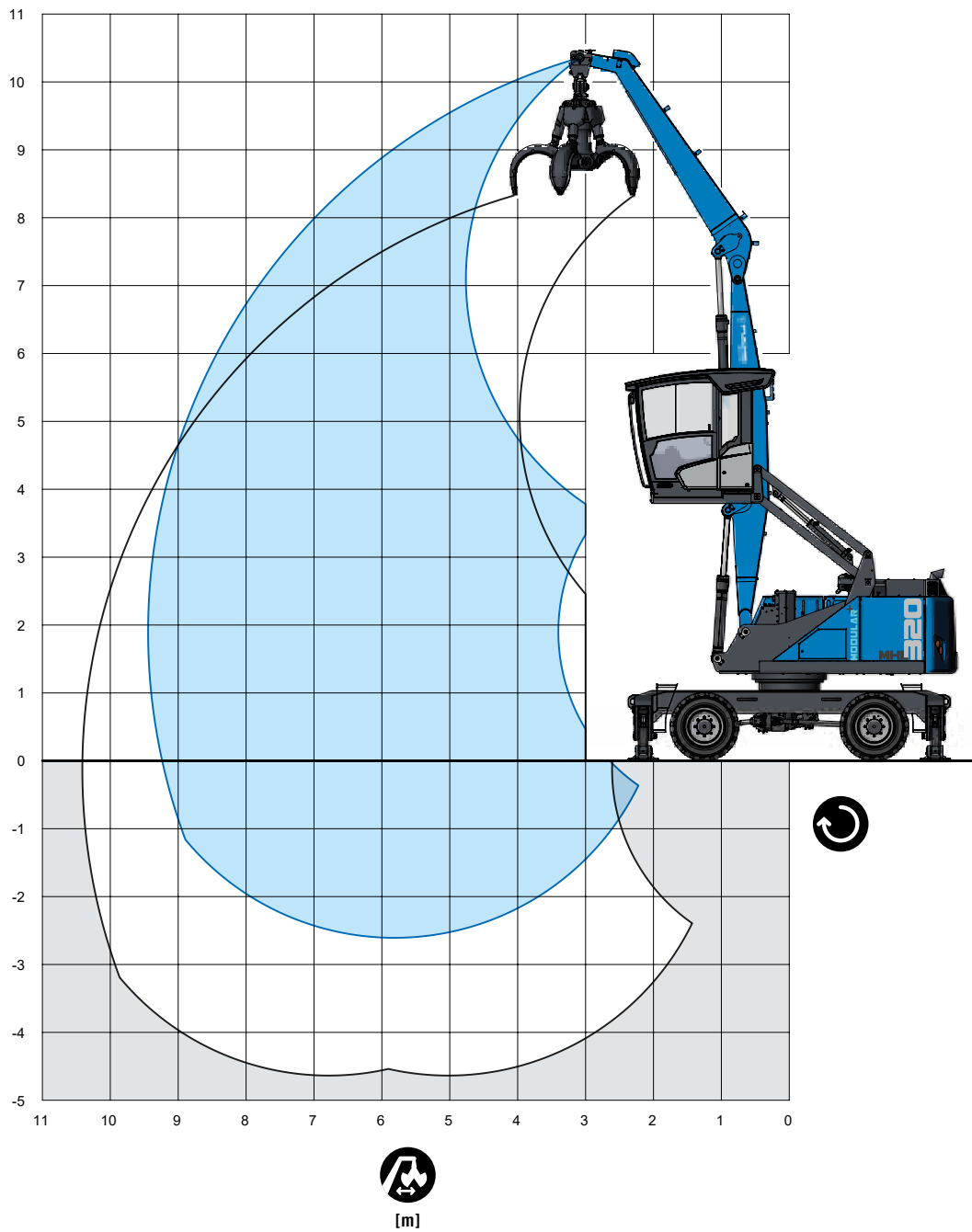























REACH

9.5 m with dipper stick

Boom: 5.2 m · Dipper stick: 4 m · Fuchs cactus grab



LIFTING CAPACITY

		  			
		4.5 m	6 m	7.5 m	9 m
9 m		(6.5°)			
		6.5° (6.5°)			
		6.5° (6.5°)			
7.5 m			(4.6)		
			5.7° (5.7°)		
			5.7° (5.7°)		
6 m			(4.5)	(3.2)	
			5.7° (5.7°)	4.9° (4.9°)	
			5.7° (5.7°)	4.0 (4.9°)	
4.5 m		(6.9)	(4.4)	(3.2)	(2.4)
		7.5° (7.5°)	6.0° (6.0°)	4.9° (4.9°)	3.8 (4.0°)
		7.5° (7.5°)	5.6 (6.0°)	4.0 (4.9°)	3.0 (4.0°)
3 m		(6.5)	(4.3)	(3.1)	(2.3)
		8.5° (8.5°)	6.3° (6.3°)	5.0° (5.0°)	3.8 (3.9°)
		8.4 (8.5°)	5.4 (6.3°)	3.9 (5.0°)	2.9 (3.9°)
1.5 m		(6.1)	(4.1)	(3.0)	(2.3)
		9.2° (9.2°)	6.5° (6.5°)	4.9° (4.9°)	3.7° (3.7°)
		8.0 (9.2°)	5.2 (6.5°)	3.8 (4.9°)	2.9 (3.7°)
0 m		(5.9)	(3.9)	(2.9)	(2.3)
		8.6° (8.6°)	6.2° (6.2°)	4.5° (4.5°)	3.1° (3.1°)
		7.7 (8.6°)	5.0 (6.2°)	3.7 (4.5°)	2.9 (3.1°)
-1.5 m		(5.8)	(3.9)	(2.9)	
		6.8° (6.8°)	5.1° (5.1°)	3.6° (3.6°)	
		6.8° (6.8°)	5.0 (5.1°)	3.6° (3.6°)	
					max. reach 9.5 m
1.9 m					(2.2)
					3.4° (3.4°)
					2.7 (3.4°)

Recommended attachments upon request



Height



Reach



Center of rotation



4-point supported

The lift capacity values are stated in metric tons (t). In accordance with ISO 10567, the lift capacity values represents 75 % of the static tipping loads or 87% of the hydraulic lifting force (marked *). On solid and level ground the values apply to a swing range of 360°. The (...) values apply in the longitudinal direction of the undercarriage. The weights of the attached load hoisting equipment (grab, load hook, etc.) must be deducted from the lift capacity values. The working load of the lifting device must be observed. In accordance with the EN 474-5 for object handling application hose rupture valves on the boom and stick cylinders, an overload warning device and the lift capacity table in the cab are required. The machine has to be supported on a level ground for object handling application.







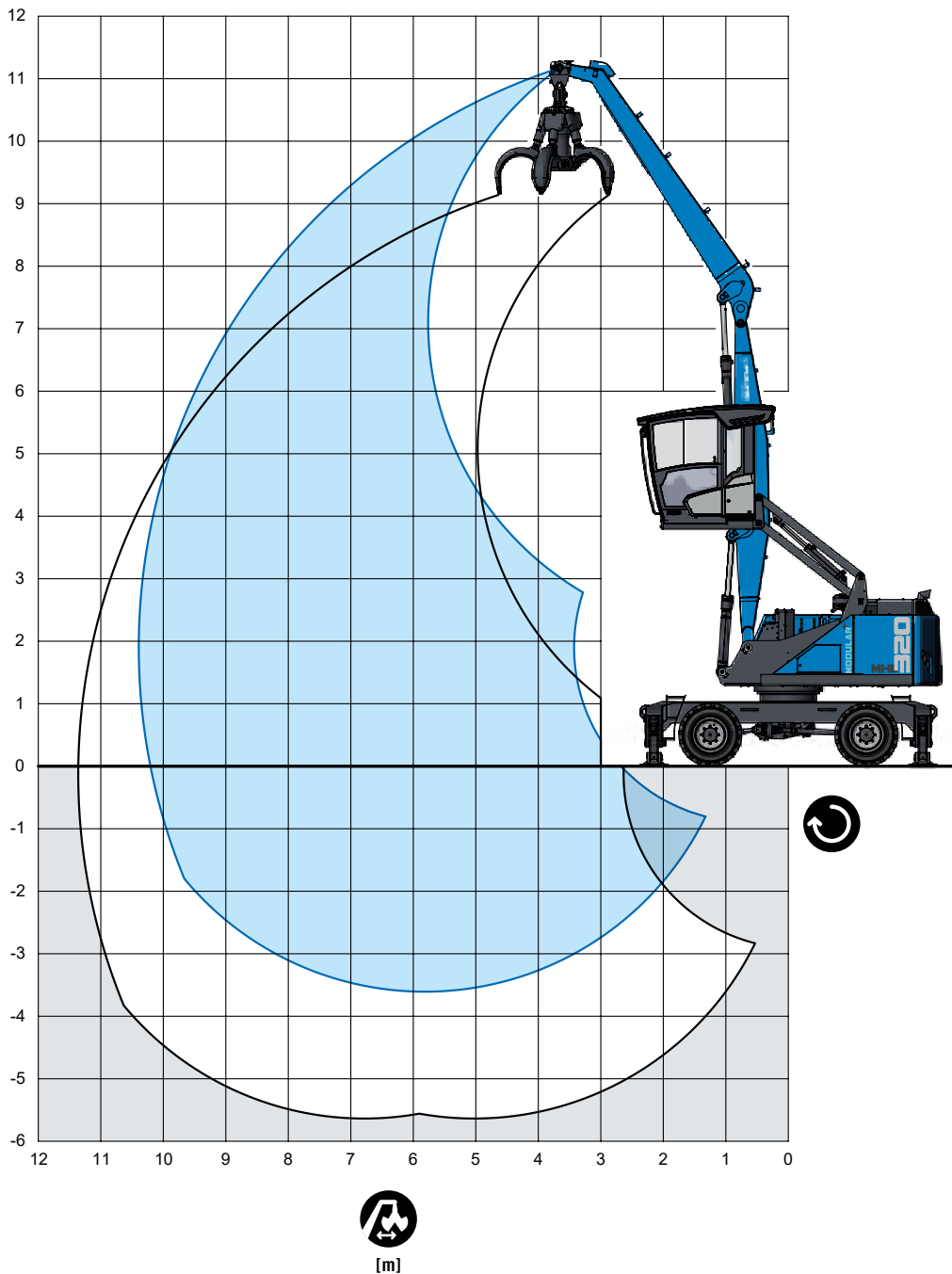





























REACH

10.4 m with dipper stick

Boom: 5.2 m · Dipper stick: 5 m · Fuchs Cactus grab



LIFTING CAPACITY

		  			
		4.5 m	6 m	7.5 m	9 m
10.5 m		(5.2°)			
		5.2° (5.2°)			
		5.2° (5.2°)			
9 m			(4.7)		
			4.9° (4.9°)		
			4.9° (4.9°)		
7.5 m			(4.7)	(3.3)	
			5.0° (5.0°)	4.5° (4.5°)	
			5.0° (5.0°)	4.1 (4.5°)	
6 m			(4.7)	(3.3)	(2.4)
			5.1° (5.1°)	4.5° (4.5°)	3.9° (3.9°)
			5.1° (5.1°)	4.1 (4.5°)	3.1 (3.9°)
4.5 m			(4.6)	(3.2)	(2.4)
			5.4° (5.4°)	4.6° (4.6°)	3.9 (4.0°)
			5.4° (5.4°)	4.0 (4.6°)	3.0 (4.0°)
3 m		(6.8)	(4.4)	(3.1)	(2.4)
		7.6° (7.6°)	5.9° (5.9°)	4.8° (4.8°)	3.8 (4.0°)
		7.6° (7.6°)	5.5 (5.9°)	3.9 (4.8°)	3.0 (4.0°)
1.5 m		(6.3)	(4.2)	(3.0)	(2.3)
		8.7° (8.7°)	6.3° (6.3°)	4.9° (4.9°)	3.7 (3.9°)
		8.2 (8.7°)	5.3 (6.3°)	3.8 (4.9°)	2.9 (3.9°)
0 m		(5.9)	(4.0)	(2.9)	(2.2)
		9.0° (9.0°)	6.4° (6.4°)	4.8° (4.8°)	3.6° (3.6°)
		7.8 (9.0°)	5.1 (6.4°)	3.7 (4.8°)	2.8 (3.6°)
-1.5 m		(5.7)	(3.8)	(2.8)	(2.2)
		8.1° (8.1°)	5.8° (5.8°)	4.3° (4.3°)	3.0° (3.0°)
		7.6 (8.1°)	4.9 (5.8°)	3.6 (4.3°)	2.8 (3.0°)
-3 m		(5.7)	(3.8)	(2.8)	
		6.0° (6.0°)	4.4° (4.4°)	3.1° (3.1°)	
		6.0° (6.0°)	4.4° (4.4°)	3.1° (3.1°)	
					max. reach 10.4 m
1.9 m					(1.9)
					3.0° (3.0°)
					2.4 (3.0°)

Recommended attachments upon request



Height



Reach



Center of rotation



4-point supported

The lift capacity values are stated in metric tons (t). In accordance with ISO 10567, the lift capacity values represents 75 % of the static tipping loads or 87% of the hydraulic lifting force (marked *). On solid and level ground the values apply to a swing range of 360°. The (...) values apply in the longitudinal direction of the undercarriage. The weights of the attached load hoisting equipment (grab, load hook, etc.) must be deducted from the lift capacity values. The working load of the lifting device must be observed. In accordance with the EN 474-5 for object handling application hose rupture valves on the boom and stick cylinders, an overload warning device and the lift capacity table in the cab are required. The machine has to be supported on a level ground for object handling application.







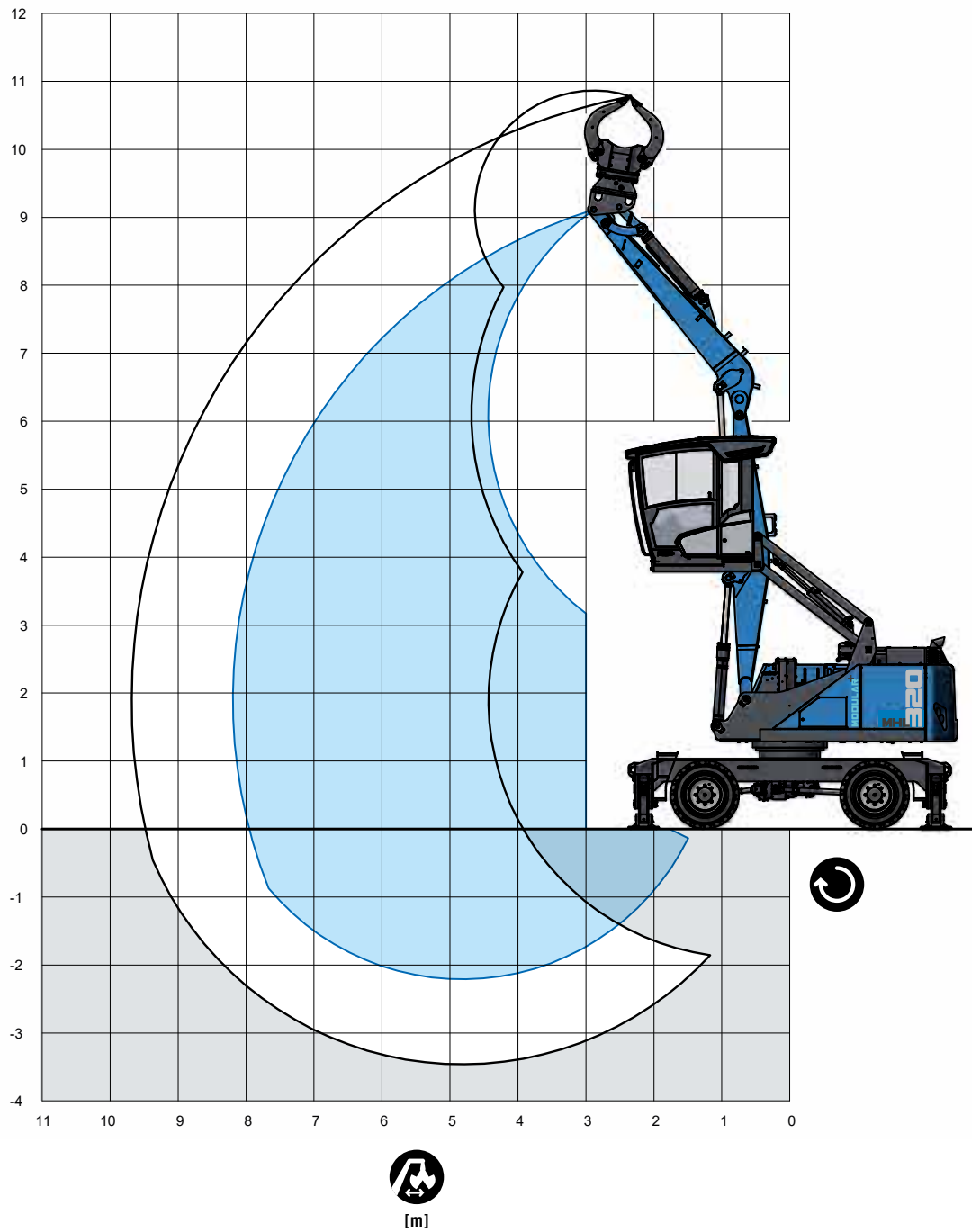



















REACH

8.2 m with multi-purpose stick

Boom: 4.2 m · Dipper stick: 3.7 m · Sorting grapple



LIFTING CAPACITY

		  			
		3 m	4.5 m	6 m	7.5 m
7.5 m			(6.8°)		
			6.8° (6.8°)		
			6.8° (6.8°)		
6 m			(6.8°)	(4.3)	
			6.8° (6.8°)	5.9° (5.9°)	
			6.8° (6.8°)	5.5 (5.9°)	
4.5 m			(6.8)	(4.3)	(3.0)
			7.2° (7.2°)	6.0° (6.0°)	4.8° (4.8°)
			7.2° (7.2°)	5.4 (6.0°)	3.8 (4.8°)
3 m		(9.4°)	(6.5)	(4.2)	(2.9)
		9.4° (9.4°)	8.2° (8.2°)	6.3° (6.3°)	4.8 (4.9°)
		9.4° (9.4°)	8.2° (8.2°)	5.3 (6.3°)	3.7 (4.9°)
1.5 m		(10.5)	(6.2)	(4.0)	(2.9)
		10.5 (10.5)	9.1° (9.1°)	6.4° (6.4°)	4.7° (4.7°)
		10.5 (10.5)	8.1 (9.1°)	5.1 (6.4°)	3.7 (4.7°)
0 m		(7.4°)	(5.9)	(3.9)	(2.8)
		7.4° (7.4°)	8.8° (8.8°)	6.0° (6.0°)	4.0° (4.0°)
		7.4° (7.4°)	7.8 (8.8°)	5.0 (6.0°)	3.6 (4.0°)
-1.5 m		(8.0°)	(5.8)	(3.8)	
		8.0° (8.0°)	6.9° (6.9°)	4.5° (4.5°)	
		8.0° (8.0°)	6.9° (6.9°)	4.5° (4.5°)	
					max. reach 8.1 m
1.9 m					(2.5)
					4.0° (4.0°)
					3.2 (4.0°)

Recommended attachments upon request



Height



Reach



Center of rotation



4-point supported

The lift capacity values are stated in metric tons (t). In accordance with ISO 10567, the lift capacity values represents 75 % of the static tipping loads or 87% of the hydraulic lifting force (marked *). On solid and level ground the values apply to a swing range of 360°. The (...) values apply in the longitudinal direction of the undercarriage. The weights of the attached load hoisting equipment (grab, load hock, etc.) must be deducted from the lift capacity values. The working load of the lifting device must be observed. In accordance with the EN 474-5 for object handling application hose rupture valves on the boom and stick cylinders, an overload warning device and the lift capacity table in the cab are required. The machine has to be supported on a level ground for object handling application.







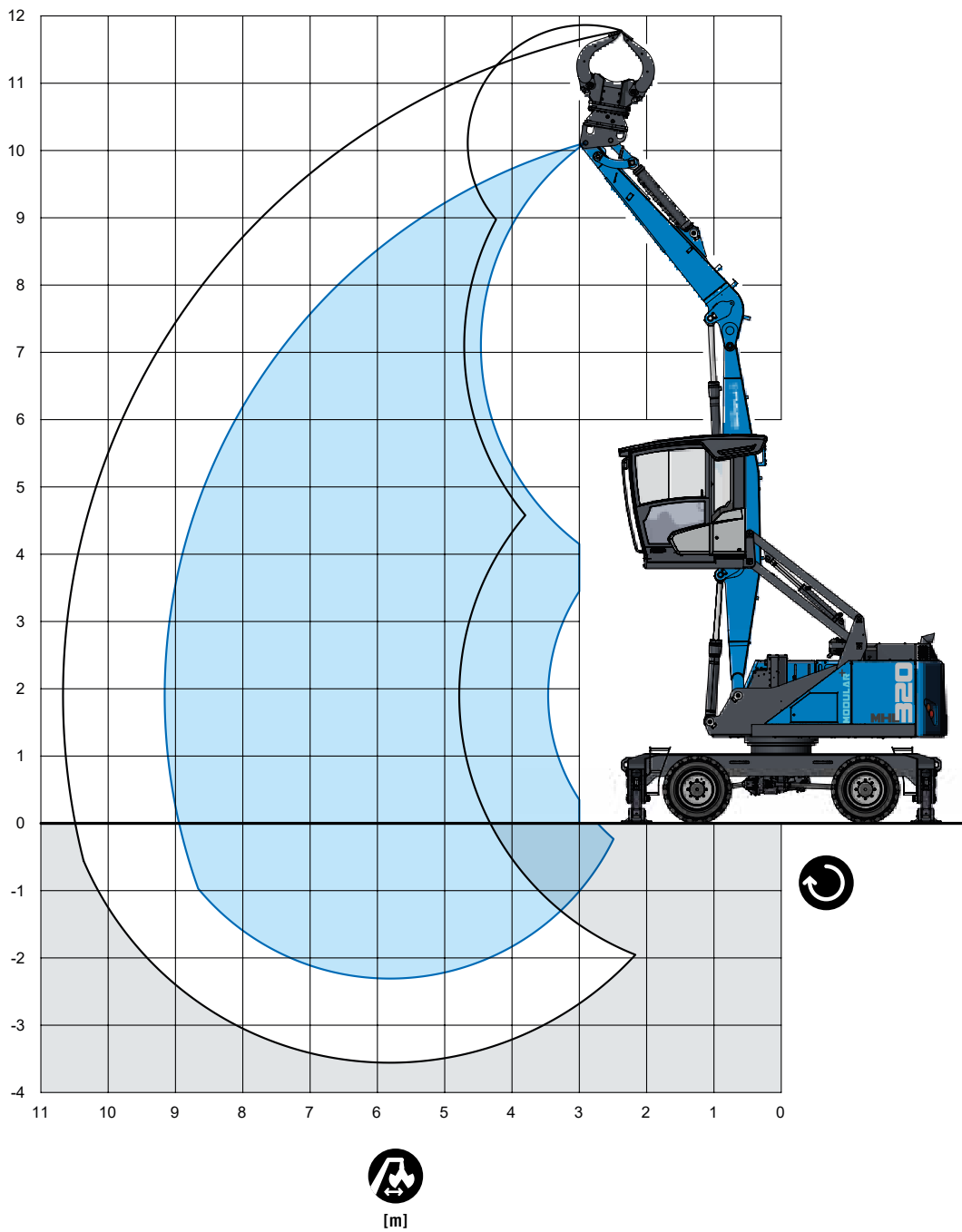























REACH

9.2 m with multi-purpose stick

Boom: 5.2 m banana boom · Dipper stick: 3.7 m · Sorting grapple



LIFTING CAPACITY

		  			
		4.5 m	6 m	7.5 m	9 m
9 m		(6.5°)			
		6.5° (6.5°)			
		6.5° (6.5°)			
7.5 m		(6.8°)	(4.3)		
		6.8° (6.8°)	5.6° (5.6°)		
		6.8° (6.8°)	5.5 (5.6°)		
6 m		(6.9°)	(4.3)	(3.0)	
		6.9° (6.9°)	5.6° (5.6°)	4.7° (4.7°)	
		6.9° (6.9°)	5.5 (5.6°)	3.8 (4.7°)	
4.5 m		(6.6)	(4.2)	(2.9)	
		7.5° (7.5°)	5.8° (5.8°)	4.7° (4.7°)	
		7.5° (7.5°)	5.3 (5.8°)	3.7 (4.7°)	
3 m		(6.2)	(4.0)	(2.8)	(2.1)
		8.4° (8.4°)	6.1° (6.1°)	4.7° (4.7°)	3.6° (3.6°)
		8.1 (8.4°)	5.1 (6.1°)	3.6 (4.7°)	2.7 (3.6°)
1.5 m		(5.8)	(3.8)	(2.7)	(2.1)
		8.8° (8.8°)	6.2° (6.2°)	4.6° (4.6°)	3.2° (3.2°)
		7.7 (8.8°)	4.9 (6.2°)	3.5 (4.6°)	2.7 (3.2°)
0 m		(5.6)	(3.7)	(2.7)	
		8.0° (8.0°)	5.7° (5.7°)	4.1° (4.1°)	
		7.4 (8.0°)	4.8 (5.7°)	3.5 (4.1°)	
-1.5 m		(5.5)	(3.6)	(2.6)	
		6.0° (6.0°)	4.4° (4.4°)	3.0° (3.0°)	
		6.0° (6.0°)	4.4° (4.4°)	3.0° (3.0°)	
					max. reach 9.2 m
1.9 m					(2.0)
					3.2° (3.2°)
					2.6 (3.2°)

Recommended attachments upon request



Height



Reach



Center of rotation



4-point supported

The lift capacity values are stated in metric tons (t). In accordance with ISO 10567, the lift capacity values represents 75 % of the static tipping loads or 87% of the hydraulic lifting force (marked *). On solid and level ground the values apply to a swing range of 360°. The (...) values apply in the longitudinal direction of the undercarriage. The weights of the attached load hoisting equipment (grab, load hock, etc.) must be deducted from the lift capacity values. The working load of the lifting device must be observed. In accordance with the EN 474-5 for object handling application hose rupture valves on the boom and stick cylinders, an overload warning device and the lift capacity table in the cab are required. The machine has to be supported on a level ground for object handling application.

MODULAR SYSTEM

Attachments



Cactus grab



Timber grapple



Magnet plate

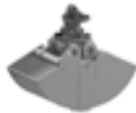

Clamshell grab



Load hook



Sorting grapple



LOADING EQUIPMENT



Straight



Multi-purpose stick

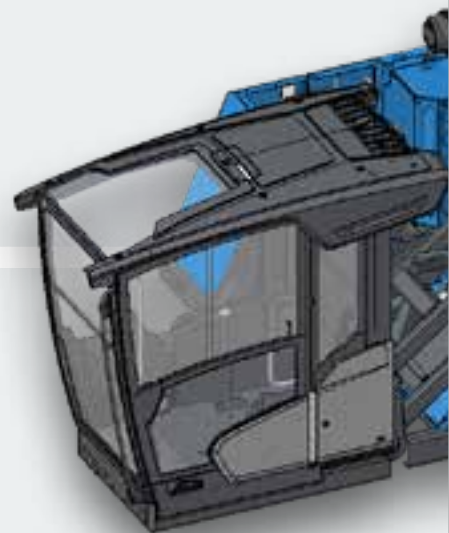

Undercarriage



Standard-undercarriage



0.8 m



Standard-undercarriage



1.4 m



XL-undercarriage



Crawler

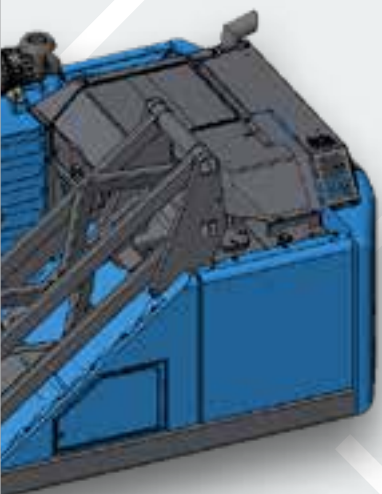

Cab Systems



Vertically adjustable

Engines



Diesel engine

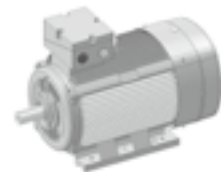

Electric motor

Options

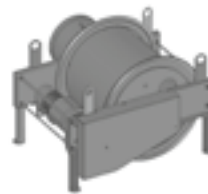

Cable drum



Crawler

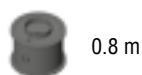

0.8 m

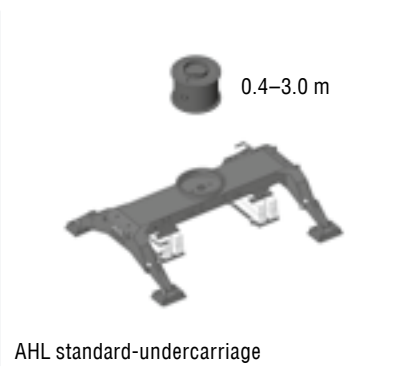

AHL standard-undercarriage

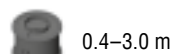

0.4-3.0 m



AHL Pylon

0.6-3.0 m



www.terex-fuchs.com

January 2023. Product specifications and prices are subject to change without notice or obligation. The photographs and/or drawings in this document are for illustrative purposes only. Refer to the appropriate Operator's Manual for instructions on the proper use of this equipment. Failure to follow the appropriate Operator's Manual when using our equipment or to otherwise act irresponsibly may result in serious injury or death. The only warranty applicable to our equipment is the standard written warranty applicable to the particular product and sale and Terex makes no other warranty, express or implied. © Terex Corporation 2022 - Terex, the Terex Crown design, Fuchs and Works For You are trademarks of Terex Corporation or its subsidiaries.

Terex® Deutschland GmbH | Industriestraße 3 | 76669 Bad Schönborn | Germany | Fon: +49 (0) 7253 84-0 | Fax: +49 (0) 7253 84-102 | info@terex-fuchs.com

